

INSTRUÇÃO DE MONTAGEM

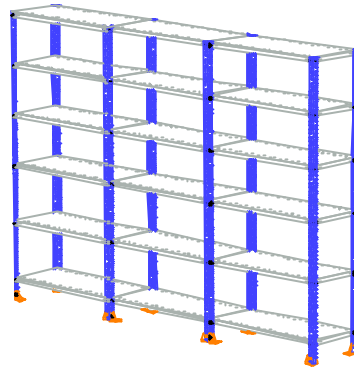

ESTANTE FORMANDO UM CONJUNTO SIMPLES

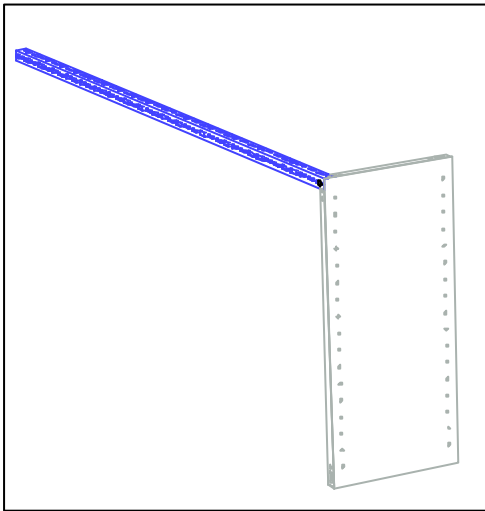

1º Passo: Colocar a ultima Prateleira na parte superior da coluna e fixar com 01 parafuso e 01 porca.

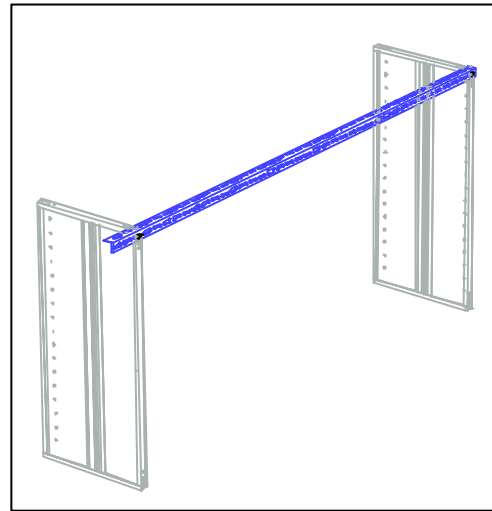

2º Passo: Colocar a primeira Prateleira a 150mm da parte superior da Prateleira até o chão, e fixar com 01 parafuso e 01 porca.

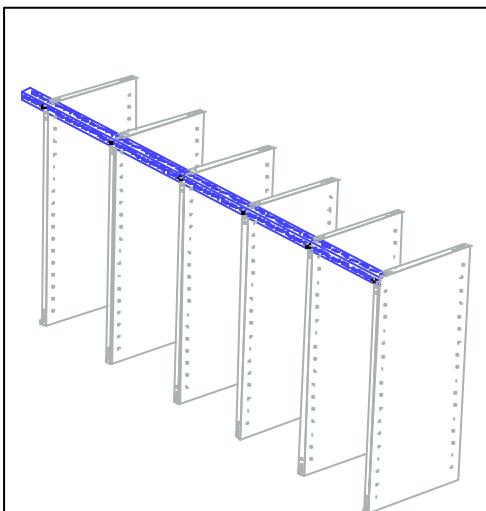

3º Passo: Colocar as demais Prateleiras intermediárias de acordo com a sua necessidade e fixar com 01 parafuso e 01 porca cada prateleira

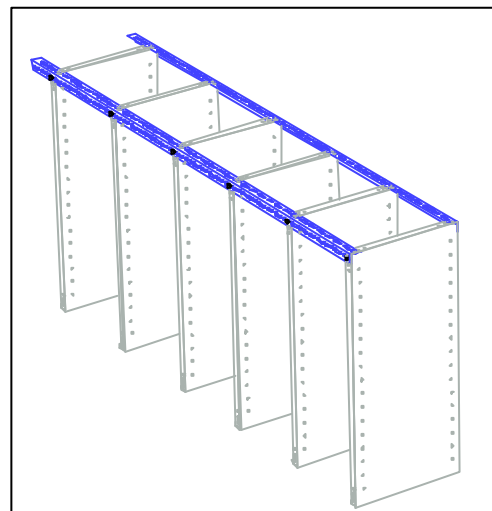

4º Passo: Colocar a 2º coluna fixando cada prateleira com 01 parafusos e 01 porca. Manter a lateral da estante sem parafuso e sem porca.

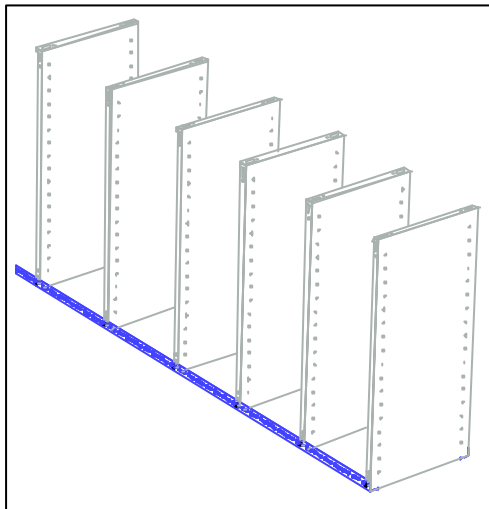

5º Passo : Virar a estante

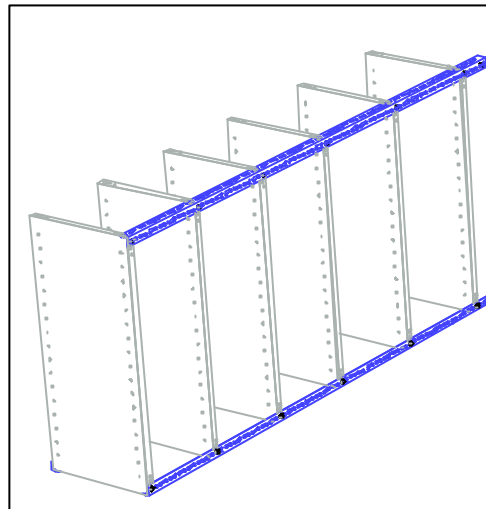

6º Passo: Colocar a 3ª coluna fixando com parafusos e porcas.

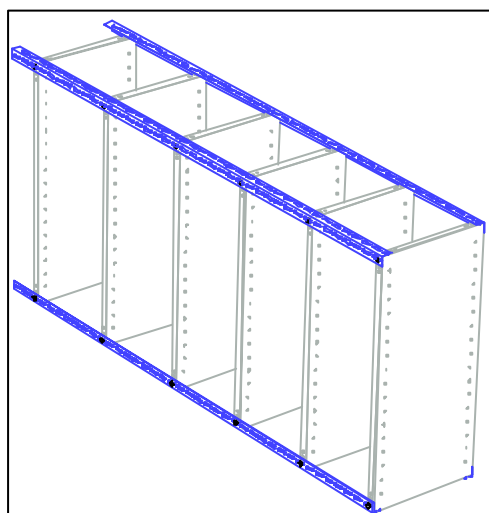

7º Passo: Colocar a 4ª coluna fixando com parafusos e porcas.
Manter a lateral da estante sem parafuso e sem porca.

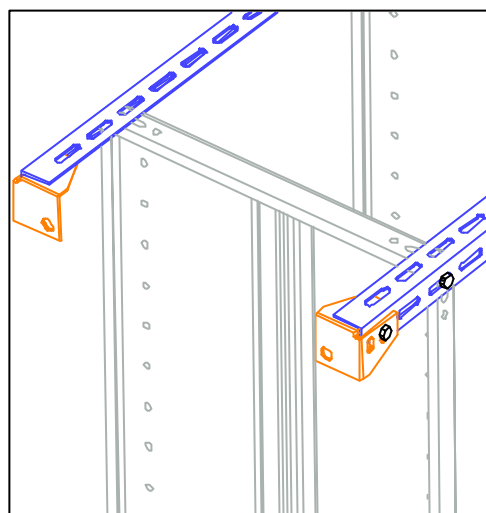

8º Passo: Colocar as Sapatas nas colunas e fixar com apenas um parafuso e uma porca .

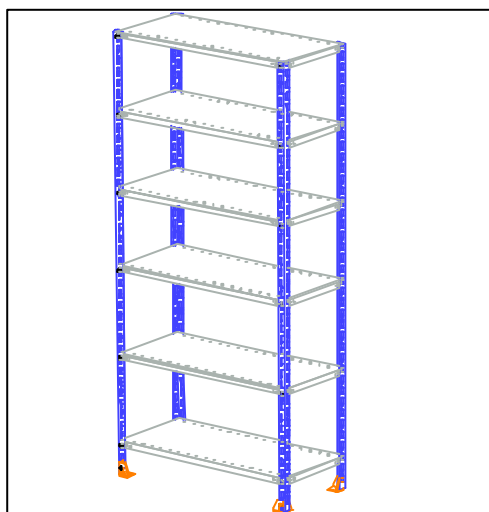

9º Passo: Levantar a estante, montar as demais estantes igualmente para serem unidas posteriormente.

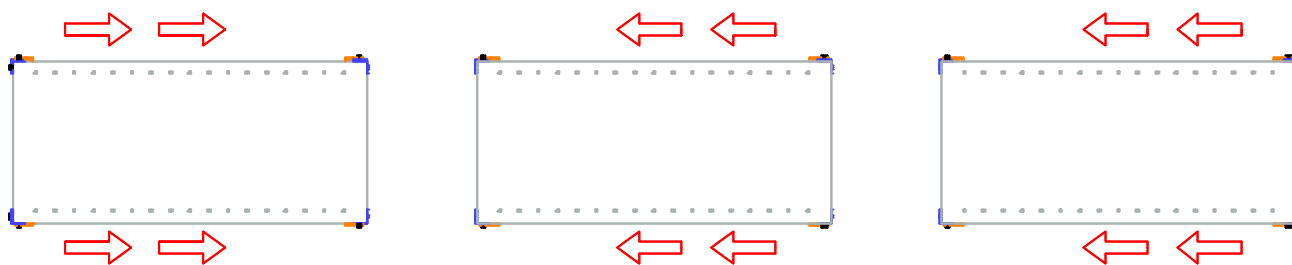

VISTA SUPERIOR



JUNÇÃO DAS ESTANTES

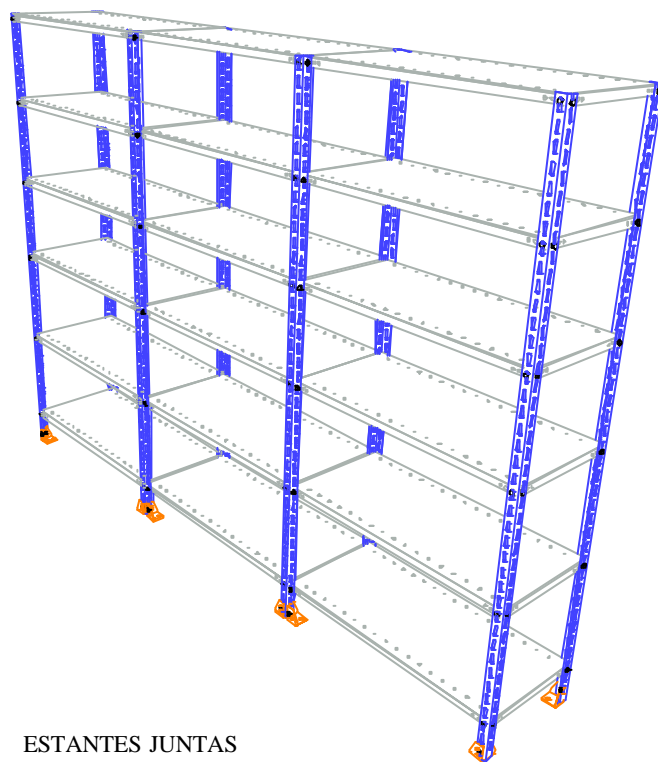

ESTANTES JUNTAS



VISTA SUPERIOR

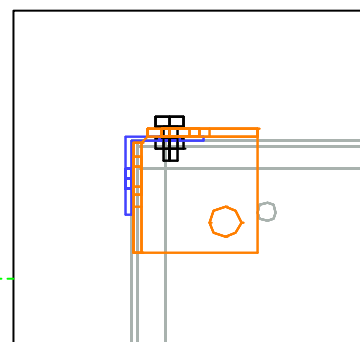
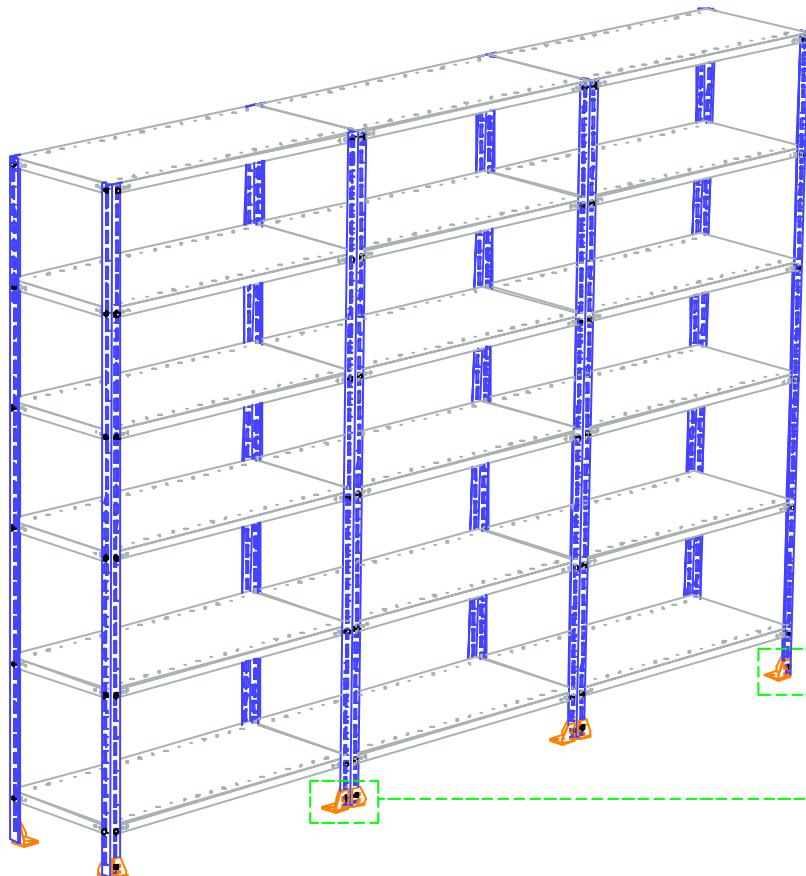
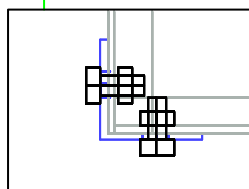
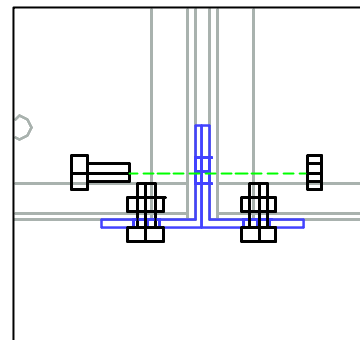

A colocação das sapadas nas colunas é feita através de um parafuso e uma porca na vista frontal da estante.

